

THIS DOCUMENT AND THE DATA DISCLOSED HEREIN OR HEREWITH IS NOT TO BE REPRODUCED, USED OR DISCLOSED IN WHOLE OR IN PART TO ANYONE WITHOUT THE PERMISSION OF VICOR CORP.

REV	DESCRIPTION	DATE	APPROVED
1	RELEASED PER E050348	11/15/05	ECF
2	REVISED PER E072386	10/02/07	REJH
3	REVISED PER E090033	01/09/09	REJH
4	REVISED PER E091548	09/03/09	REJH
5	REDRAWN PER E100902	7/14/10	KUK

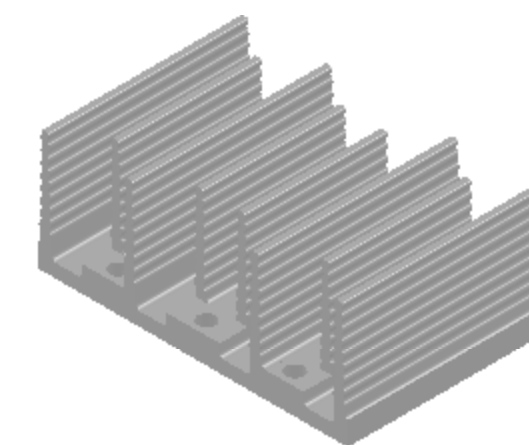
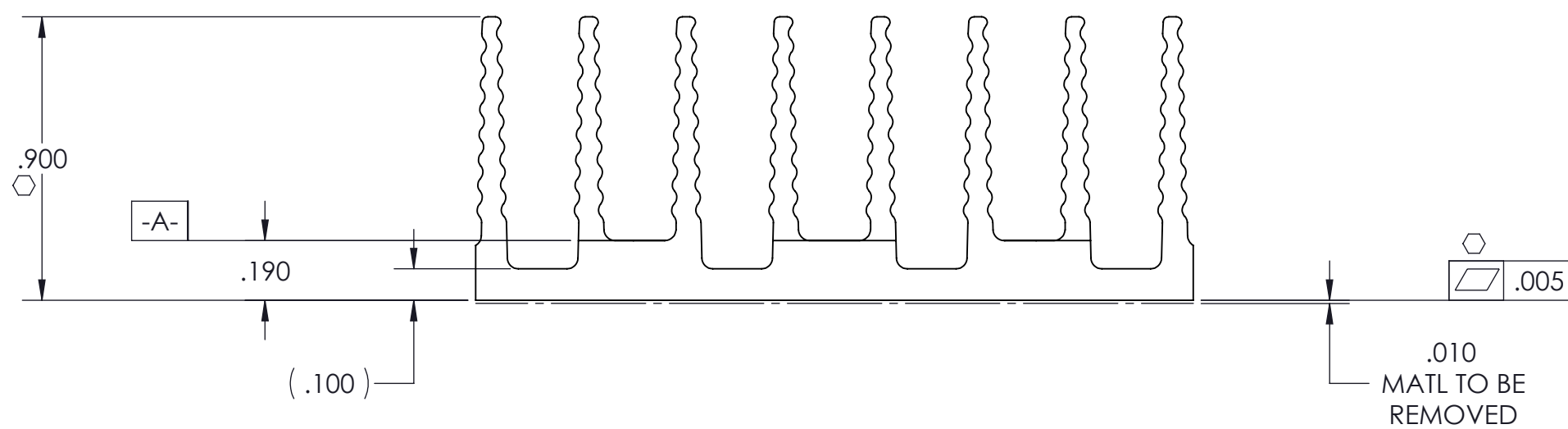
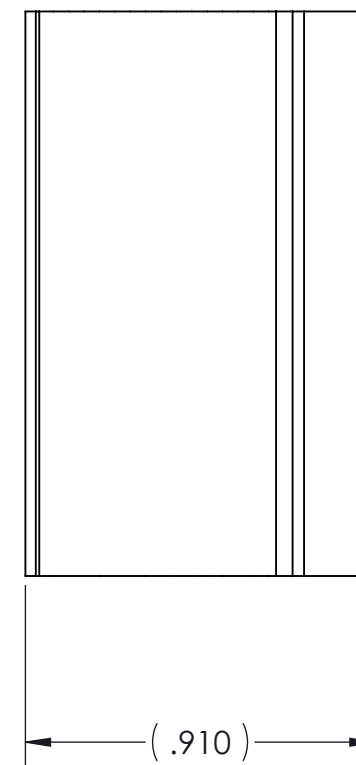
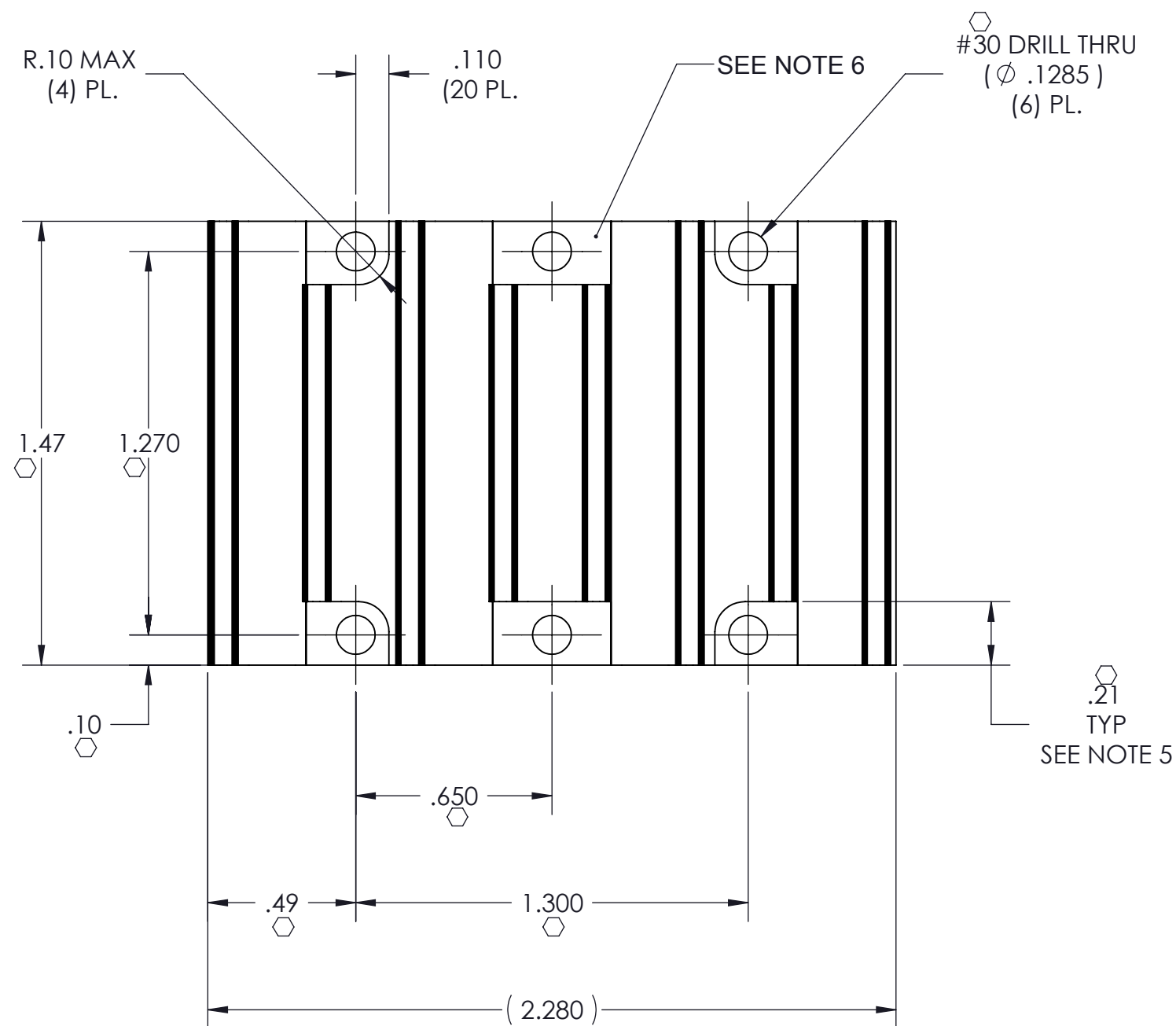

NOTES:

1. MATERIAL: EXTRUSION SEE SHEET 2 OF 2.
2. REMOVE ALL BURRS AND SHARP EDGES.
3. CLEAR FINISH, RoHS COMPLIANT, CHROMIUM FREE PER CST-0001 LATEST REVISION.
4. "○" DENOTES CRITICAL CHARACTERISTIC FOR LOT INSPECTION.'
5. DIMENSIONS APPLIES AT SURFACE -A- (2) PL.
6. MACHINED SURFACE TO BE .010 MAX BELOW SURFACE -A- (6) PL.
7. DIMENSIONS ARE INCHES ONLY.

DRAWN	DATE				
D.P. KELLY	09/05				
MATERIAL	UNLESS OTHERWISE SPECIFIED DIMENSIONS ARE INCH [MM] TOLERANCES ARE: DECIMALS ANGLES X.XX [X.X] = ±0.01 [0.25] ±1° X.XXX [X.XX] = ±0.005 [0.127]	HTSNK, "C" X-FLOW, .9H LOW FLOW, THRU HOLE			
SEE NOTES					
FINISH	THIRD ANGLE PROJECTION	SIZE	CAGE CODE	DWG NO	REV
SEE NOTES		C	67131	30725	5
		SCALE 2 : 1		SHEET 1 OF 2	

8

7

6

5

4

3

2

1

VICOR CONFIDENTIAL
THIS DOCUMENT AND THE DATA DISCLOSED HEREIN OR
HEREWITH IS NOT TO BE REPRODUCED, USED OR
DISCLOSED IN WHOLE OR IN PART TO ANYONE WITHOUT
THE PERMISSION OF VICOR CORP.

REVISIONS			
REV	DESCRIPTION	DATE	APPROVED
	SEE SHEET 1 OF 2		

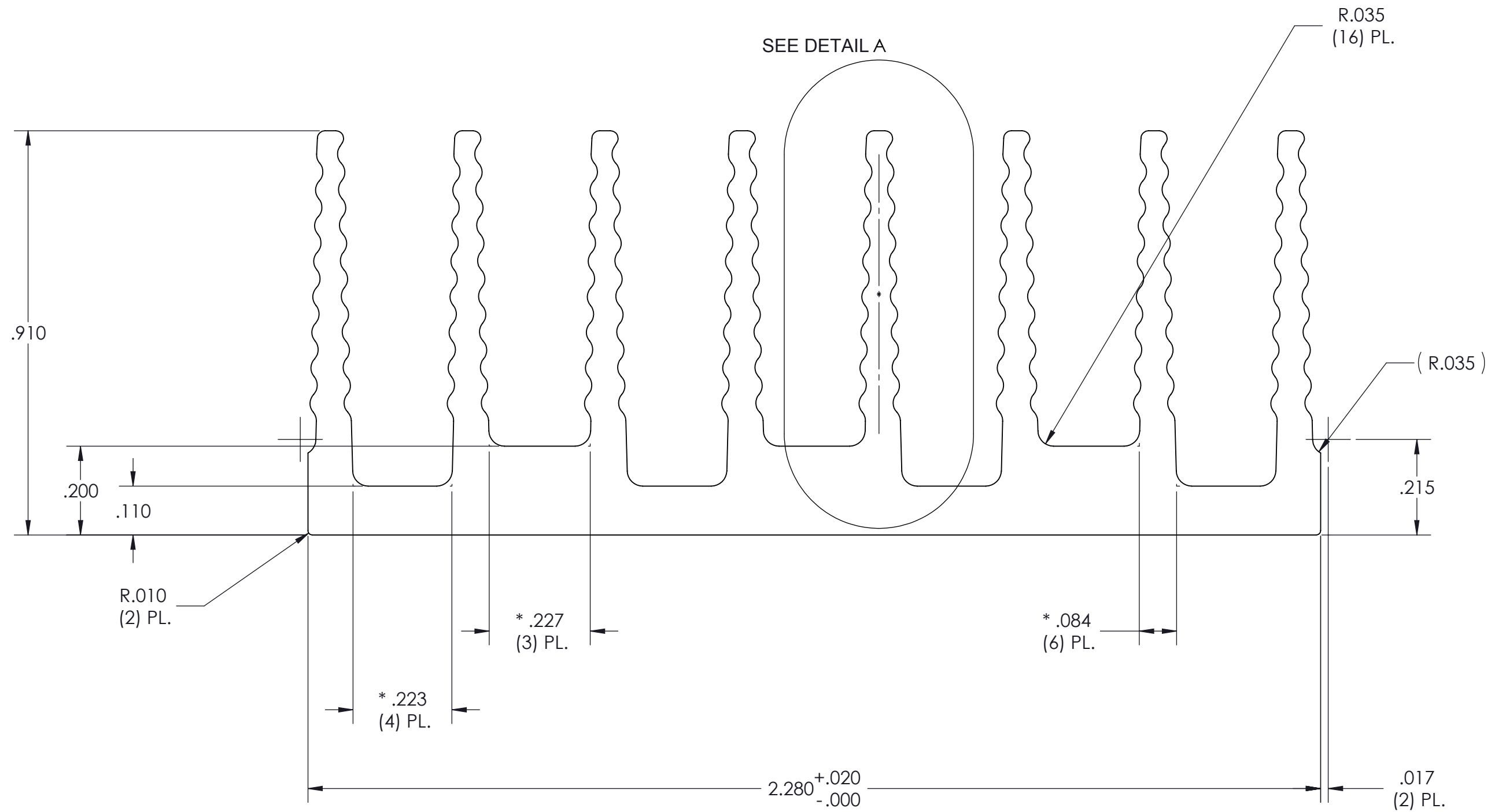

PROFILE COMMON FOR
30270
30724
30269
30725

- NOTES:
- MATL: ALUMINUM 6063-T5
 - * DENOTES DIMENSION TO THEORETICAL SHARP CORNER.
 - ALL DIMENSIONS ARE CRITICAL CHARACTERISTICS.
 - RoHS COMPLIANT PER CST-0001 LATEST REVISION.
 - WORKMANSHIP STANDARDS WS-0004, WS-0006 AND WS-0007 APPLY TO THIS PART.
 - DIMENSIONS ARE INCHES ONLY.

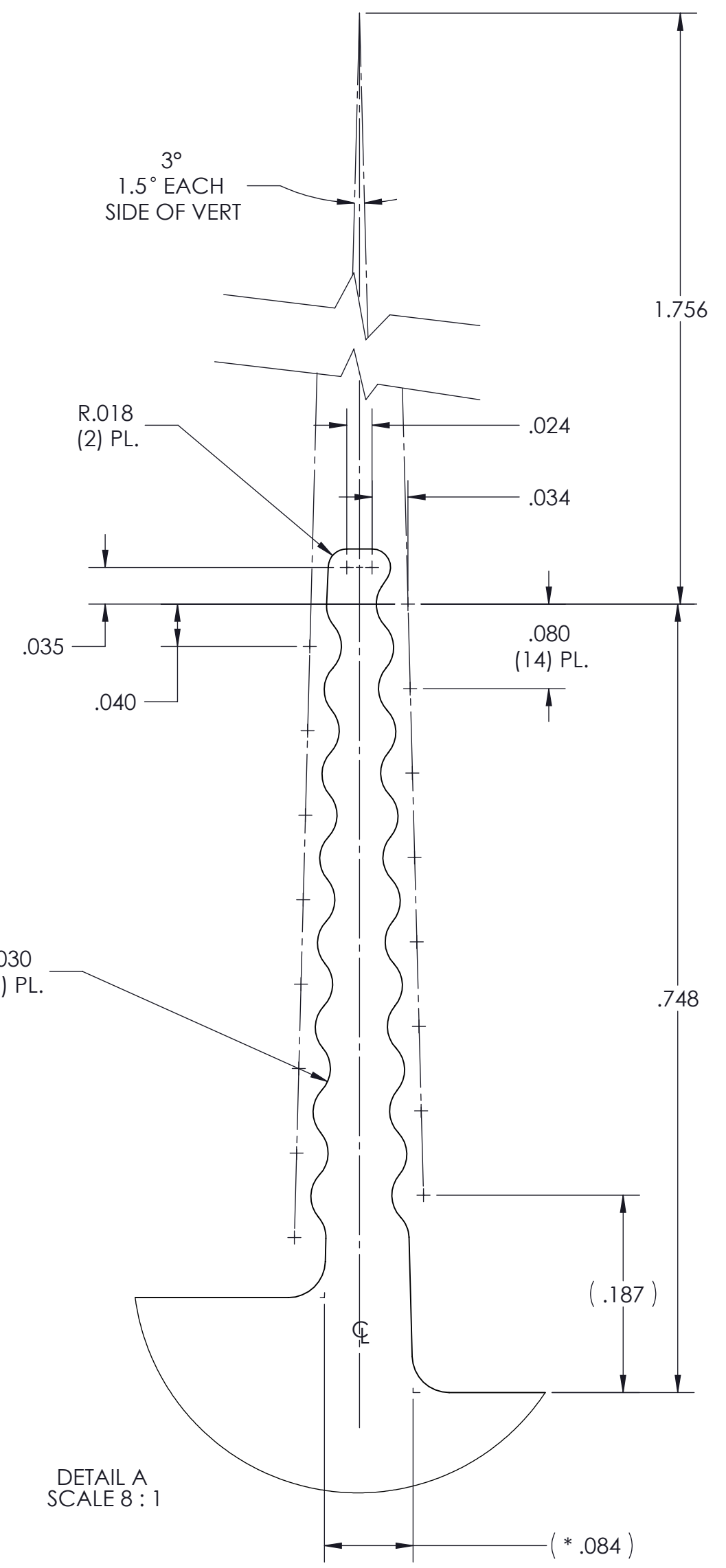

DRAWN	DATE	VICOR SWD			
JSARIPELLA	09/03/09				
MATERIAL	UNLESS OTHERWISE SPECIFIED DIMENSIONS ARE INCH [MM] TOLERANCES ARE: DECIMALS ANGLES X.XX [X.X] = ±0.01 [0.25] ±1° X.XXX [X.XX] = ±0.005 [0.127]	HTSNK, "C" X-FLOW, .9H, LOW FLOW, THRU HOLE, EXTRUSION			
SEE NOTES		SIZE	CAGE CODE	DWG NO	REV
FINISH	THIRD ANGLE PROJECTION	C	67131	30725	5
SEE NOTES	DO NOT SCALE DRAWING	SCALE 4 : 1		SHEET 2 OF 2	

8

7

6

5

4

3

2

1