

VICOR CONFIDENTIAL

THIS DOCUMENT AND THE DATA DISCLOSED HEREIN OR HEREWITH IS NOT TO BE REPRODUCED, USED OR DISCLOSED IN WHOLE OR IN PART TO ANYONE WITHOUT THE PERMISSION OF VICOR CORP.

REVISIONS

REV	DESCRIPTION	DATE	APPROVED
1	RELEASED PER E053437	LEK 11/15/05	EF
2	REVISED PER E091977a	GCK 11/2/09	MM
3	REDRAWN PER E100902	DCS 7/14/10	KUK

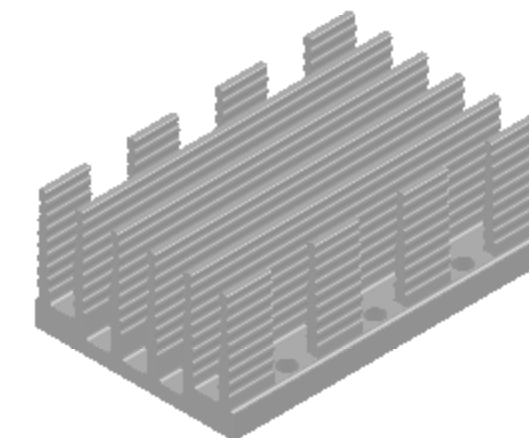
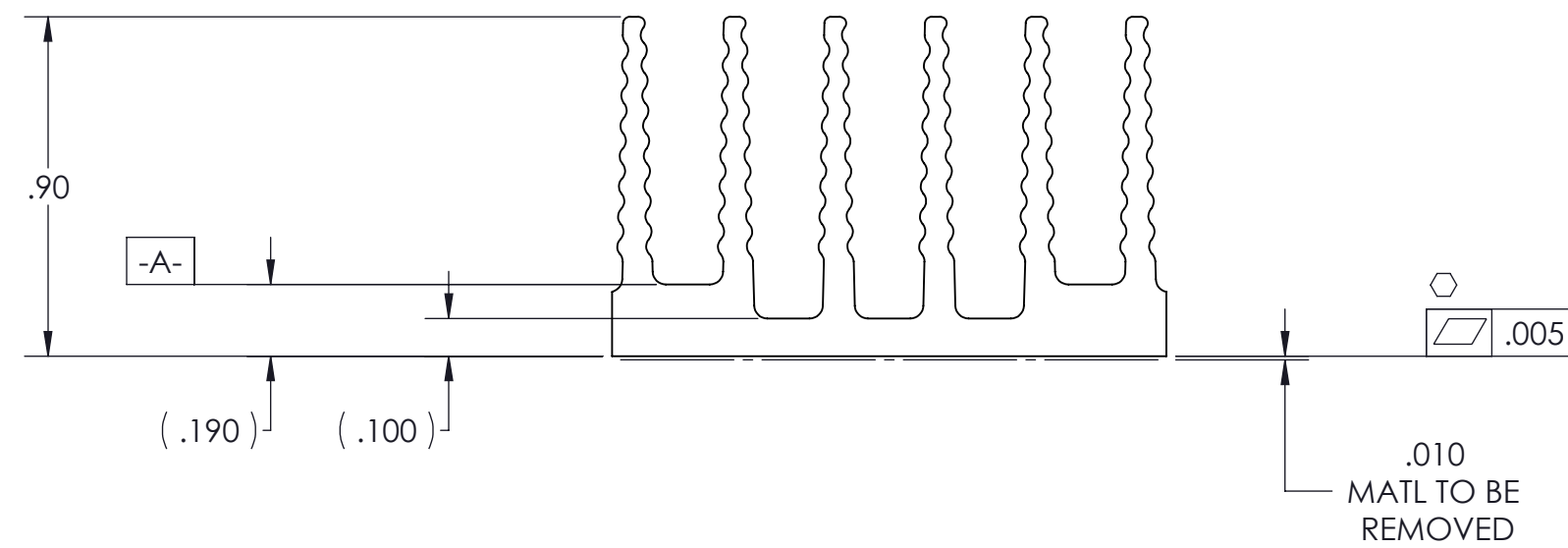
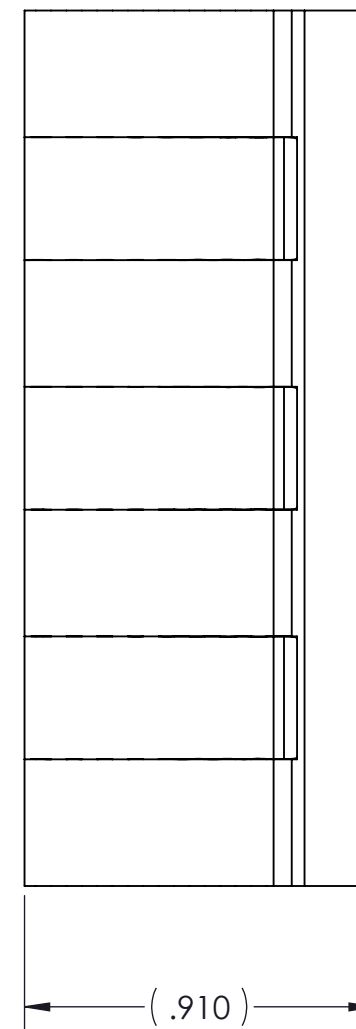
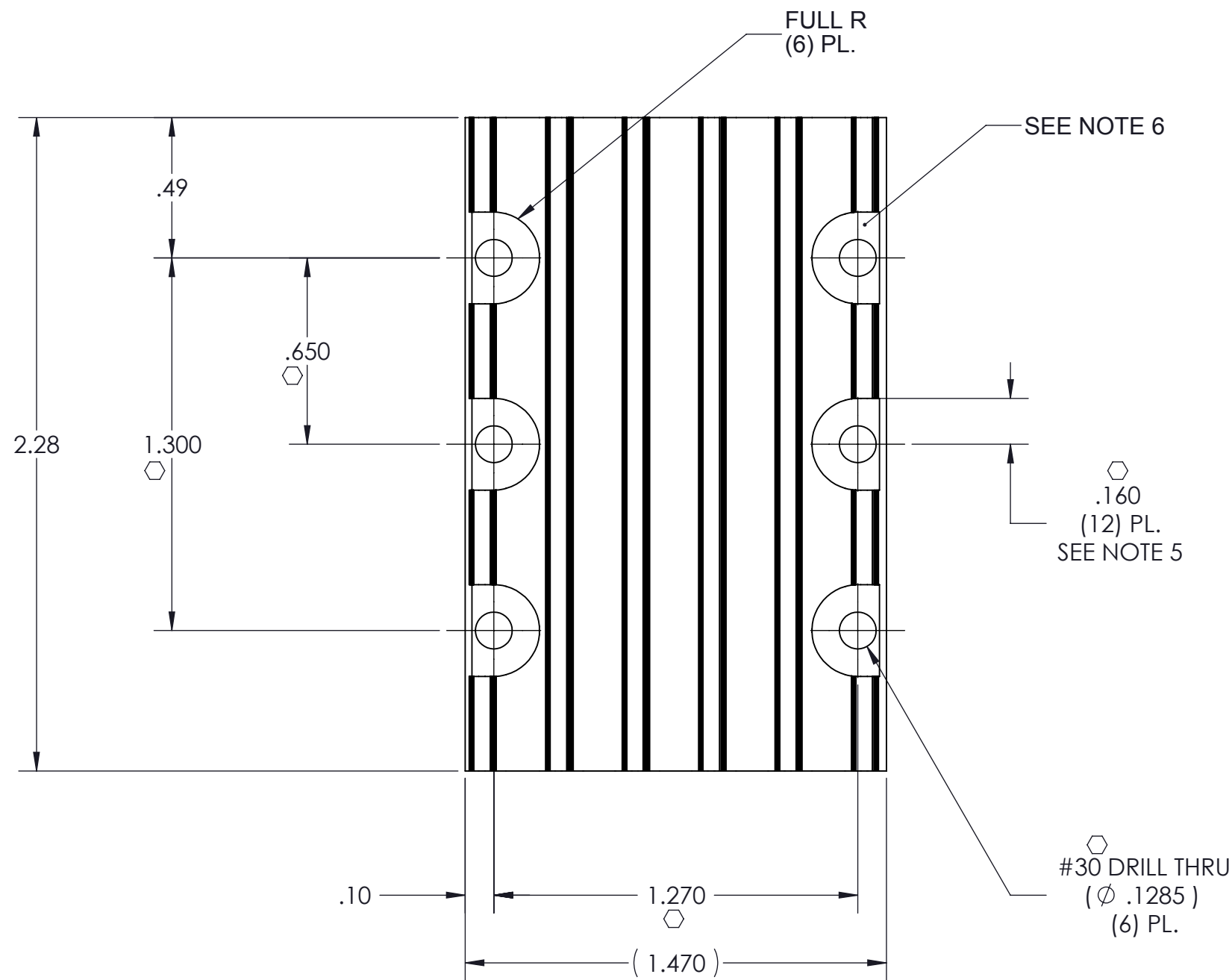

NOTES:

1. MATERIAL: EXTRUSION SEE SHEET 2 OF 2.
2. REMOVE ALL BURRS AND SHARP EDGES.
3. CLEAR FINISH, RoHS COMPLIANT, CHROMIUM FREE PER CST-0001 LATEST REVISION.
4. "○" DENOTES CRITICAL CHARACTERISTIC FOR LOT INSPECTION.'
5. DIMENSIONS APPLIES AT SURFACE -A- (12) PL.
6. MACHINED SURFACE TO BE .010 MAX BELOW SURFACE -A- (6) PL.
7. DIMENSIONS ARE INCHES ONLY.

DRAWN	DATE				
P.E.IENI	06/29/05				
MATERIAL	UNLESS OTHERWISE SPECIFIED DIMENSIONS ARE INCH [MM]	HS CFG "C" LONG, .9H LOW FLOW, THRU HOLE			
SEE NOTES	TOLERANCES ARE: DECIMALS ANGLES X.XX [X.X] = ±0.01 [0.25] ±1° X.XXX [X.XX] = ±0.005 [0.127]				
FINISH	THIRD ANGLE PROJECTION	SIZE	CAGE CODE	DWG NO	REV
SEE NOTES		C	67131	30183	3
		SCALE 2 : 1		SHEET 1 OF 2	

THIS DOCUMENT AND THE DATA DISCLOSED HEREIN OR HEREWITH IS NOT TO BE REPRODUCED, USED OR DISCLOSED IN WHOLE OR IN PART TO ANYONE WITHOUT THE PERMISSION OF VICOR CORP.

REV	DESCRIPTION	DATE	APPROVED
	SEE SHEET 1 OF 2		

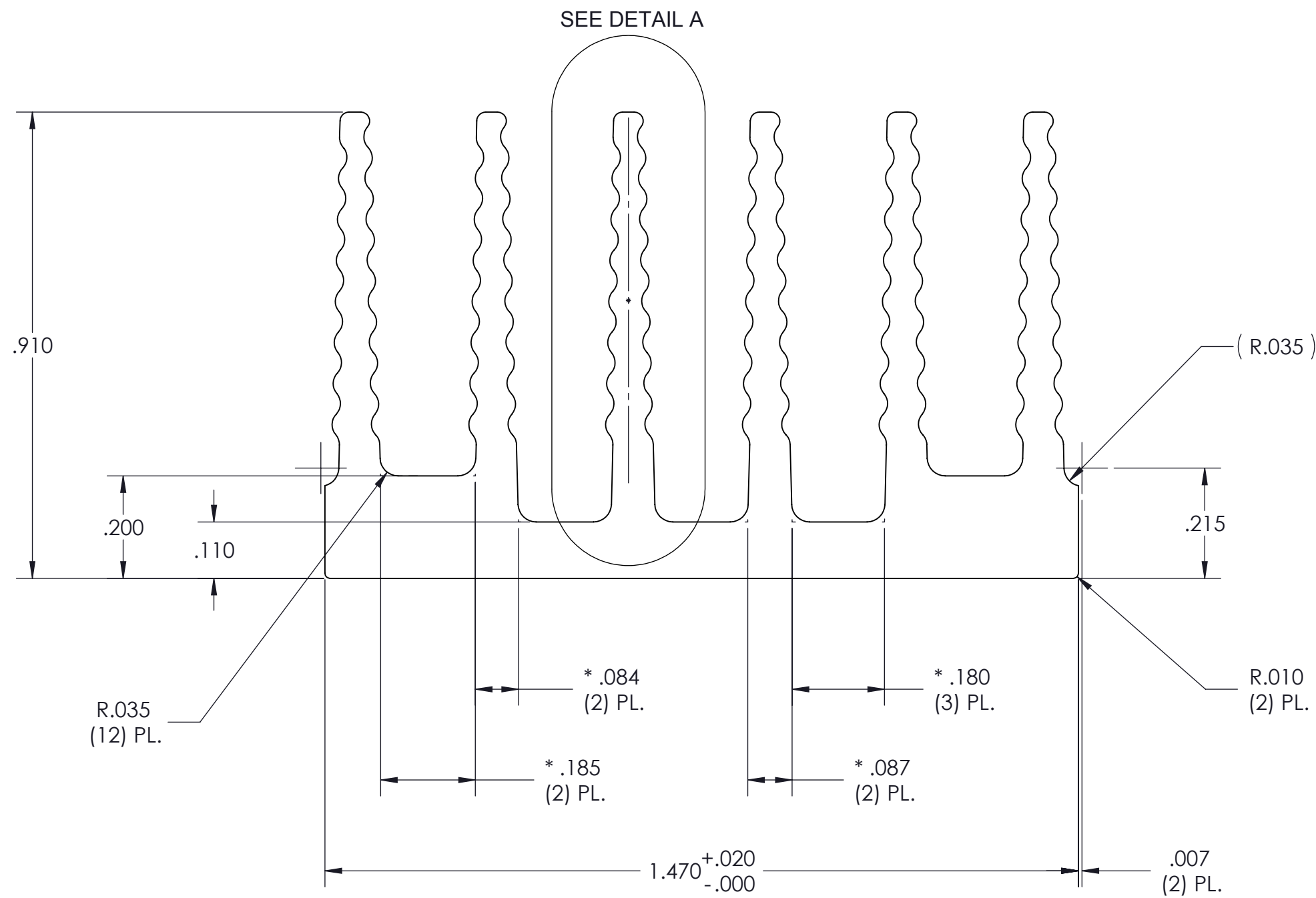

PROFILE COMMON FOR
30183
30190

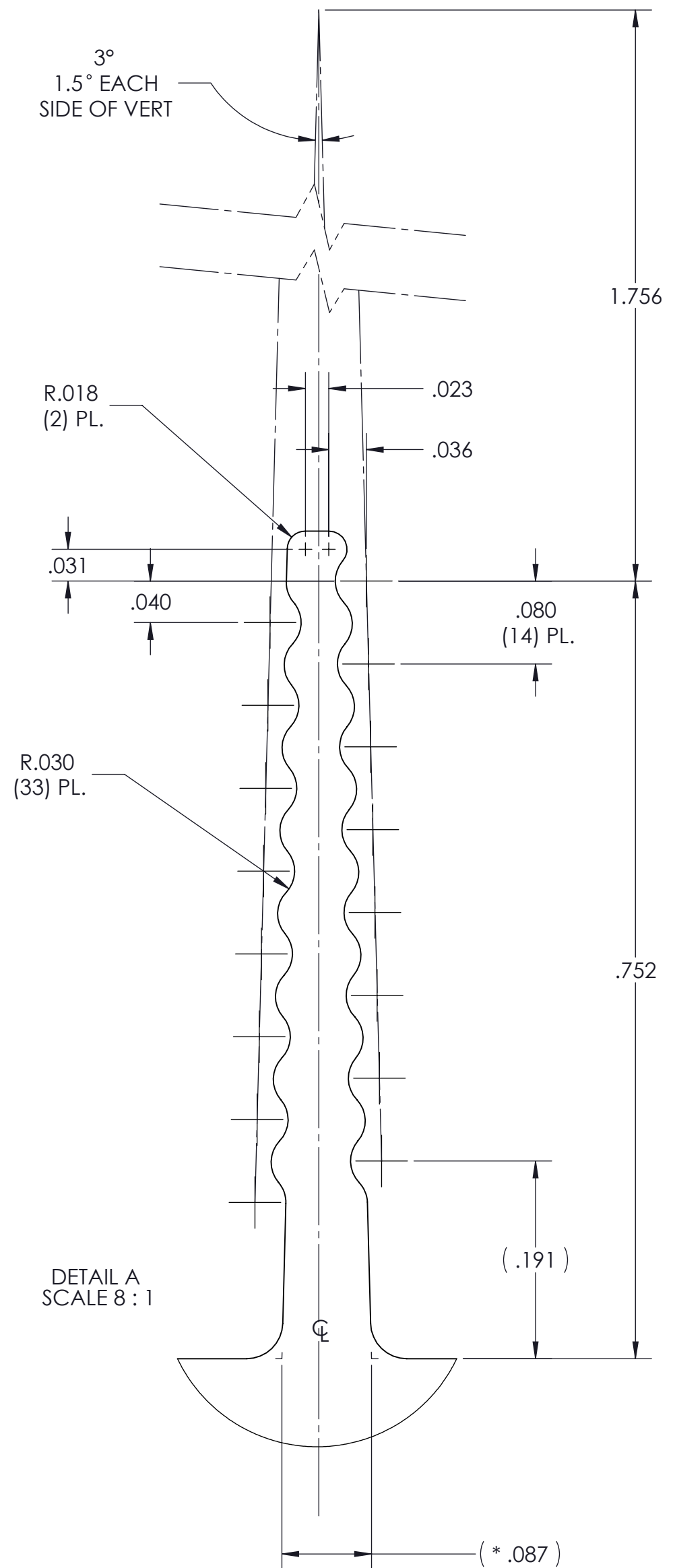

- NOTES:
1. MATL: ALUMINUM 6063-T5
 2. * DENOTES DIMENSION TO THEORETICAL SHARP CORNER.
 3. ALL DIMENSIONS ARE CRITICAL CHARACTERISTICS.
 4. RoHS COMPLIANT PER CST-0001 LATEST REVISION.
 5. WORKMANSHIP STANDARDS WS-0004, WS-0006 AND WS-0007 APPLY TO THIS PART.
 6. DIMENSIONS ARE INCHES ONLY.

DRAWN	DATE				
G. C. KEAY	11/2/09				
UNLESS OTHERWISE SPECIFIED DIMENSIONS ARE INCH [MM] TOLERANCES ARE: DECIMALS ANGLES X.XX [X.X] = ±0.01 [0.25] ±1° X.XXX [X.XX] = ±0.005 [0.127]		HS CFG "C" LONG, .9H, LOW FLOW, THRU HOLE, EXTRUSION			
MATERIAL	FINISH	SIZE	CAGE CODE	DWG NO	REV
SEE NOTES	THIRD ANGLE PROJECTION	C	67131	30183	3
DO NOT SCALE DRAWING		SCALE 4 : 1		SHEET 2 OF 2	