

THIS DOCUMENT AND THE DATA DISCLOSED HEREIN OR HEREWITH IS NOT TO BE REPRODUCED, USED OR DISCLOSED IN WHOLE OR IN PART TO ANYONE WITHOUT THE PERMISSION OF VICOR CORP.

REV	DESCRIPTION	DATE	APPROVED
1	RELEASED PER E053437	LEK 11/16/05	EF
2	RELEASED PER E072386	JS 10/01/07	REJH
3	RELEASED PER E090033	AR 01/09/09	REJH
4	REVISED PER E092035	JS 11/16/09	REJH
5	REDRAWN PER E100887	DCS 7/1/10	KUK

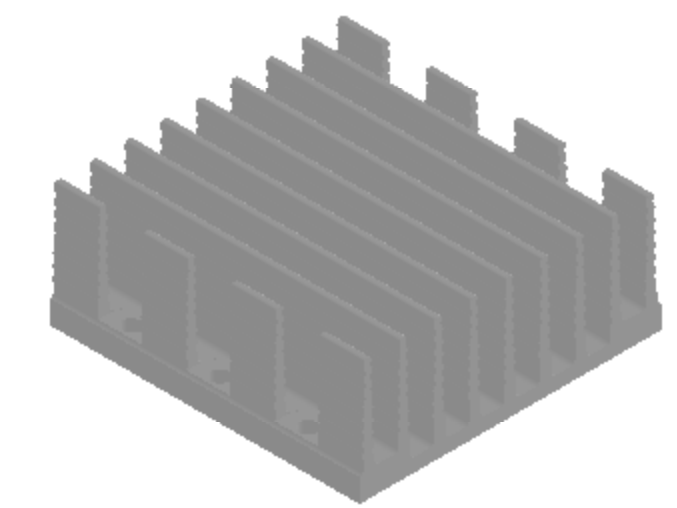
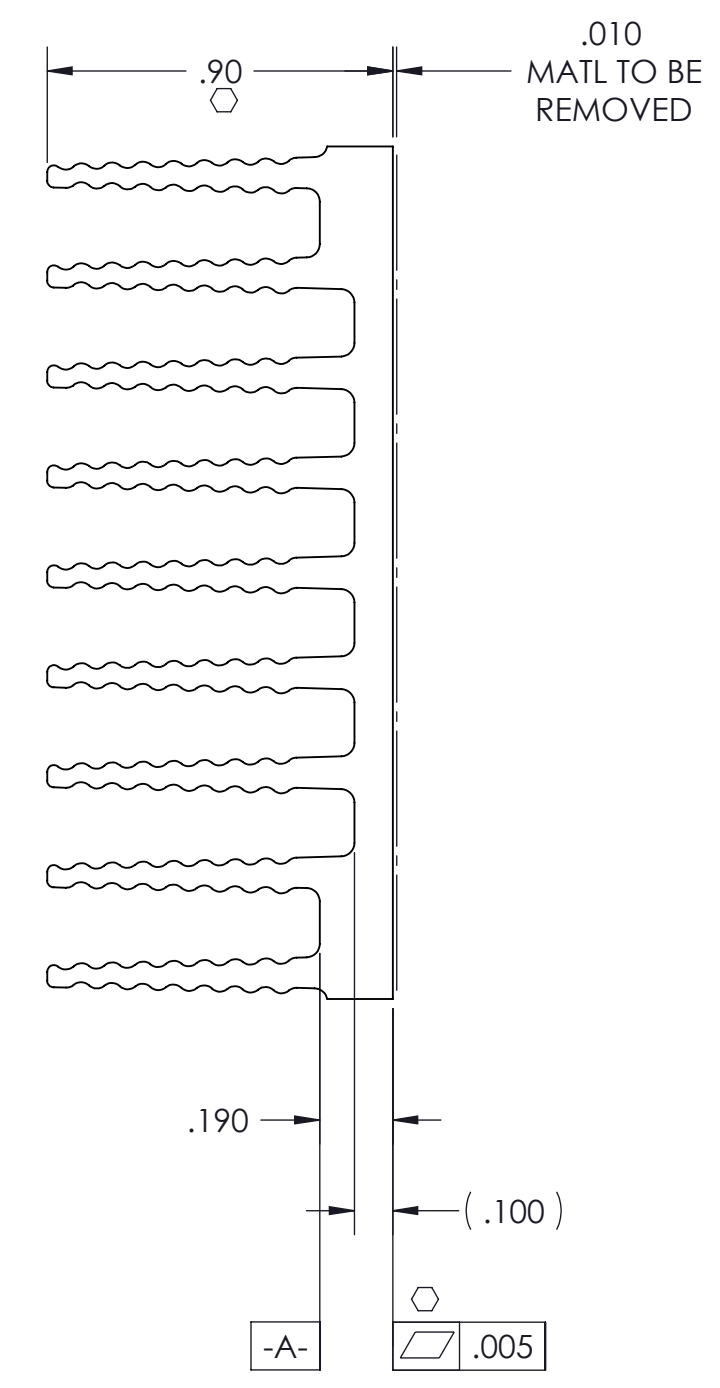
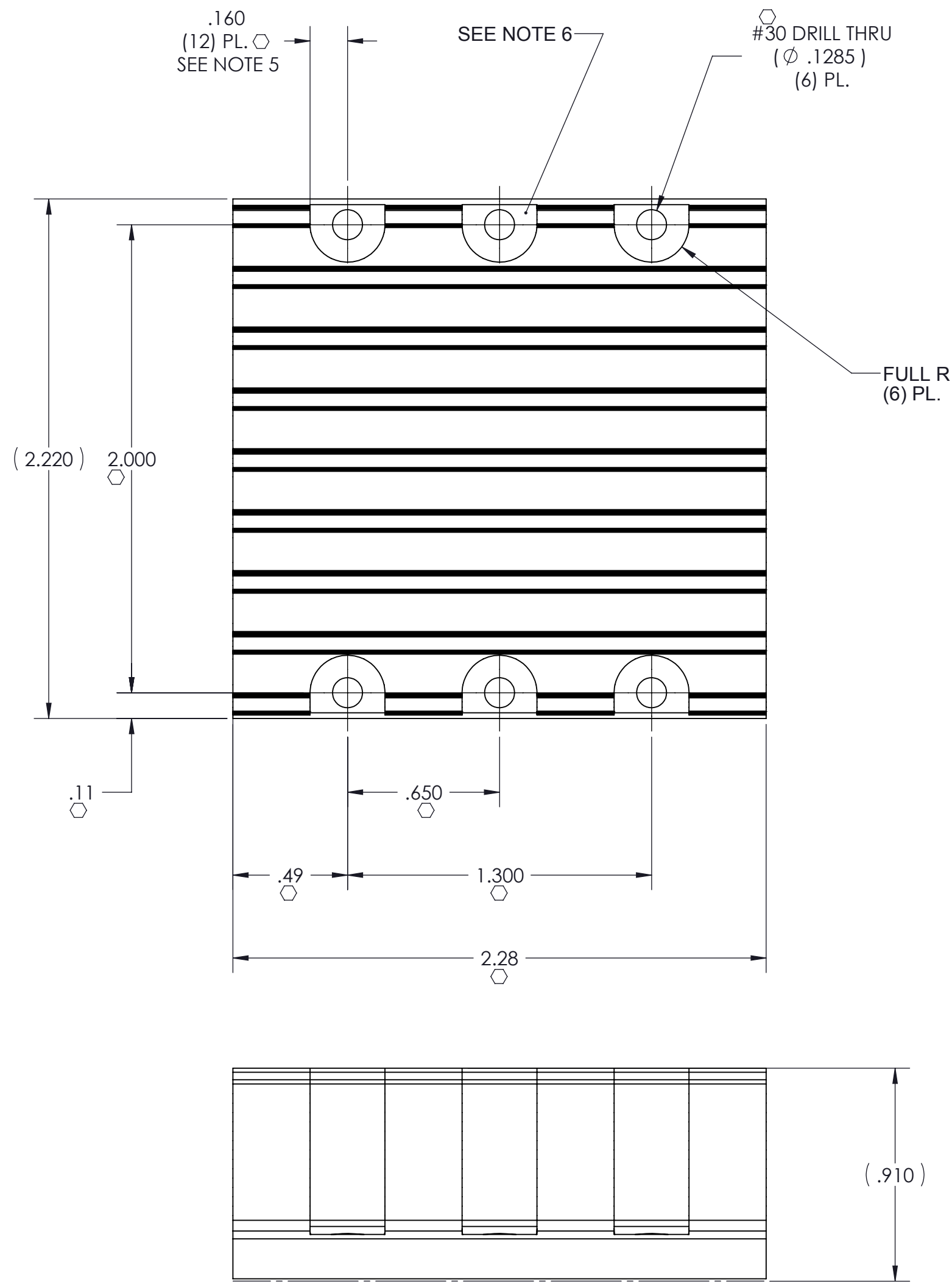

- NOTES:
1. MATERIAL: EXTRUSION SEE SHEET 2 OF 2.
 2. REMOVE ALL BURRS AND SHARP EDGES.
 3. CLEAR FINISH, RoHS COMPLIANT, CHROMIUM FREE PER CST-0001 LATEST REVISION.
 4. "□" DENOTES CRITICAL CHARACTERISTIC FOR LOT INSPECTION.'
 5. DIMENSIONS APPLIES AT SURFACE -A- (2) PL.
 6. MACHINED SURFACE TO BE .010 MAX BELOW SURFACE -A- (6) PL.
 7. DIMENSIONS ARE INCHES ONLY.

DRAWN	DATE				
P.E.IENI	06/28/05				
MATERIAL	UNLESS OTHERWISE SPECIFIED DIMENSIONS ARE INCH [MM]	HS CFG "B" LONG .9H LOW FLOW, THRU HOLE			
SEE NOTES	TOLERANCES ARE: DECIMALS ANGLES X.XX [X.X] = ±0.01 [0.25] ±1° X.XXX [X.XX] = ±0.005 [0.127]				
FINISH	THIRD ANGLE PROJECTION	SIZE	CAGE CODE	DWG NO	REV
SEE NOTES		C	67131	30182	5
		SCALE 2 : 1		SHEET 1 OF 2	

VICOR CONFIDENTIAL
 THIS DOCUMENT AND THE DATA DISCLOSED HEREIN OR
 HEREWITH IS NOT TO BE REPRODUCED, USED OR
 DISCLOSED IN WHOLE OR IN PART TO ANYONE WITHOUT
 THE PERMISSION OF VICOR CORP.

REVISIONS			
REV	DESCRIPTION	DATE	APPROVED
	SEE SHEET 1 OF 2		

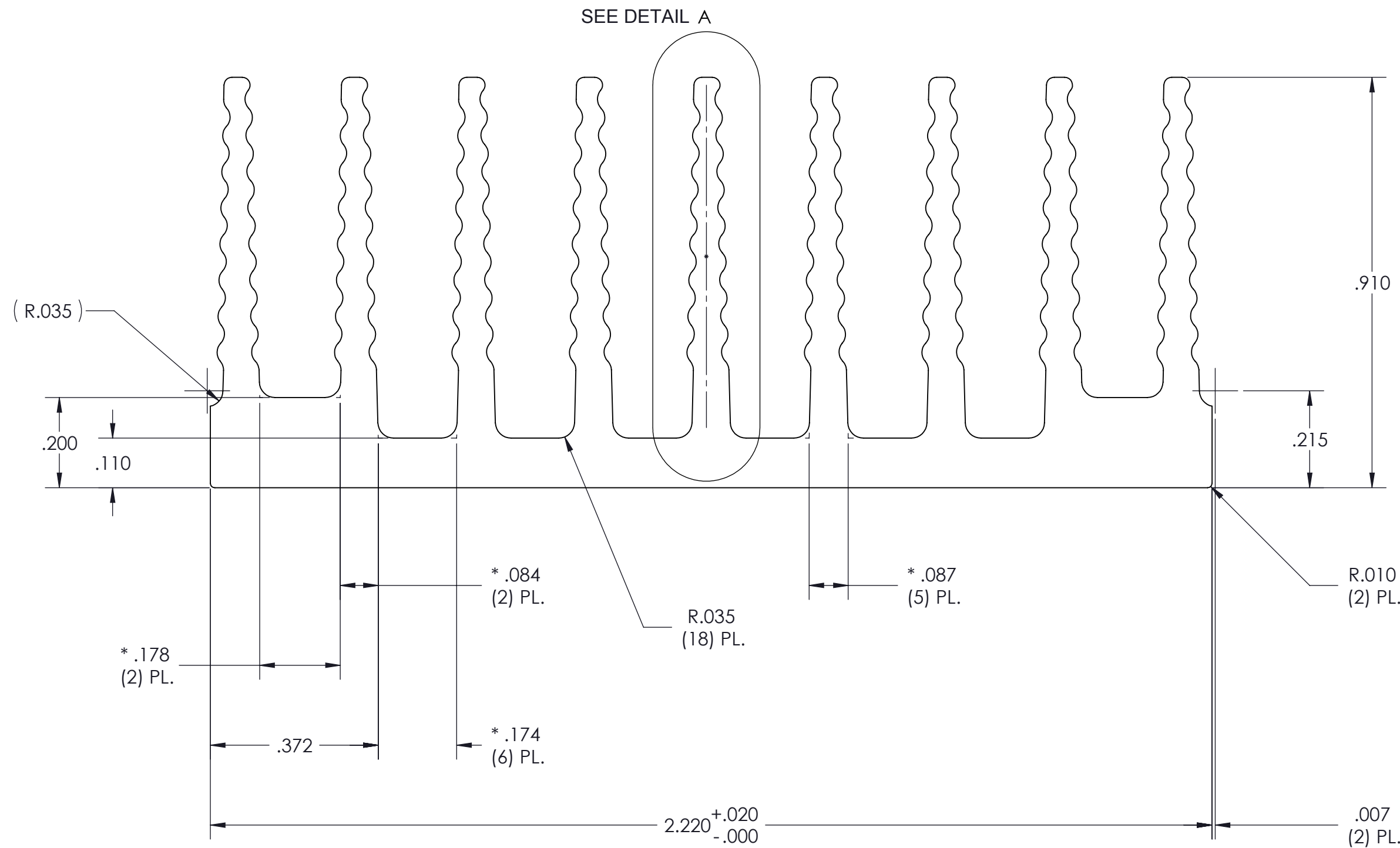

PROFILE COMMON FOR
30123
30181
30189
30182
30188

- NOTES:
1. MATERIAL: ALUMINUM 6063-T5
 2. * DENOTES DIMENSION TO THEORETICAL SHARP CORNER.
 3. ALL DIMENSIONS ARE CRITICAL CHARACTERISTICS.
 4. RoHS COMPLIANT PER CST-0001 LATEST REVISION.
 5. WORKMANSHIP STANDARDS WS-0004, WS-0006, AND WS0007 APPLY TO THIS PART.
 6. DIMENSIONS ARE INCHES ONLY.

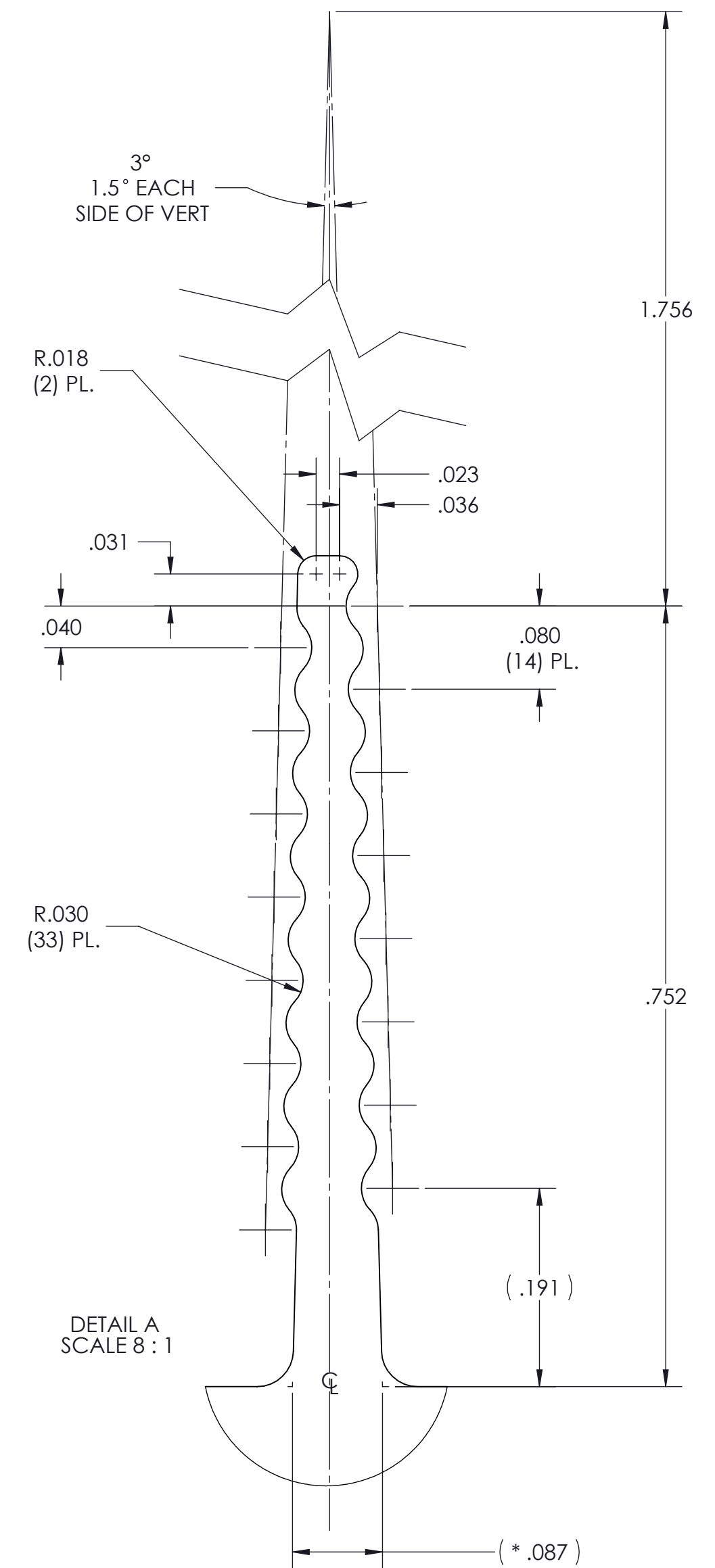

DRAWN JSARIPPELLA		DATE 11/16/09		SWD	
MATERIAL SEE NOTES		UNLESS OTHERWISE SPECIFIED DIMENSIONS ARE INCH (MM) TOLERANCES ARE: DECIMALS ANGLES X.XX [X.X] = ±0.01 [0.25] ±1° X.XXX [X.XX] = ±0.005 [0.127]		HS CFG "B" LONG .9H LOW FLOW, THRU HOLE, EXTRUSION	
FINISH SEE NOTES		THIRD ANGLE PROJECTION 	SIZE C	CAGE CODE 67131	DWG NO 30182
		DO NOT SCALE DRAWING	SCALE 4 : 1	REV 5	SHEET 2 OF 2