

8

7

6

5

4

3

2

1

VICOR CONFIDENTIAL

THIS DOCUMENT AND THE DATA DISCLOSED HEREIN OR HEREWITH IS NOT TO BE REPRODUCED, USED OR DISCLOSED IN WHOLE OR IN PART TO ANYONE WITHOUT THE PERMISSION OF VICOR CORP.

REVISIONS

REV	DESCRIPTION	DATE	APPROVED
1	RELEASED PER E080722 SA	4/9/08	REJH
2	REVISED PER E100944 KUK	07/22/10	DCS

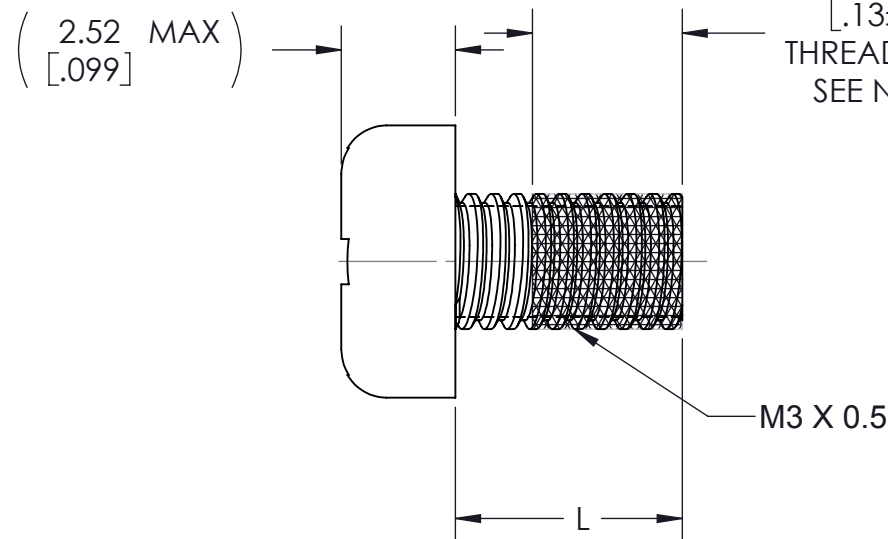
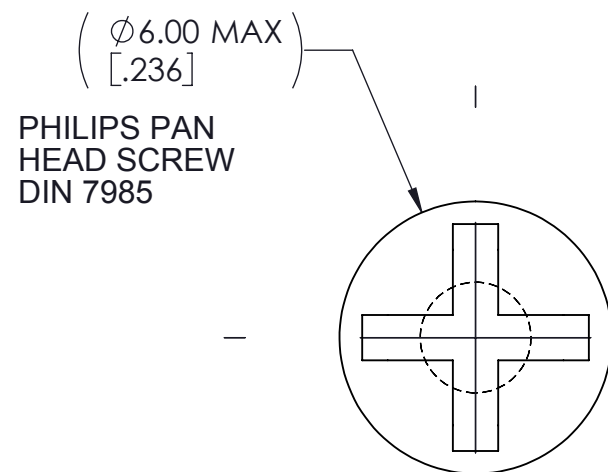

KIT #	PART # / DASH CONDITION	
34716	34706-05	L=5.0±0.3[0.20±0.01] LONG
34715	34706-06	L=6.0±0.3[0.24±0.01] LONG



- NOTES:
- MATL: STAINLESS STEEL 18-8 PASSIVATED.
  - REMOVE ALL BURRS AND SHARP EDGES.
  - MACHINE APPLY LOCTITE DRI-LOC 204 OR EQUIVALENT TO THREADS AS SHOWN.
  - RoHS COMPLIANT PER CST-0001 LATEST REVISION.

DRAWN	DATE
R.E.J.HICKEY	3/31/08

**VICOR** SWD

MATERIAL	UNLESS OTHERWISE SPECIFIED DIMENSIONS ARE MM [INCH] TOLERANCES ARE: DECIMALS      ANGLES X.XX [X.X] = ±0.01 [0.25]      ±1° X.XXX [X.XX] = ±0.005 [0.127]	<b>PHILIPS PAN HEAD SCREW M3x.5, DIN 7985, SS, WITH LOCK</b>		
FINISH		THIRD ANGLE PROJECTION 	SIZE <b>B</b>	CAGE CODE <b>67131</b>
		DWG NO <b>34706-XX</b>	REV <b>2</b>	
	DO NOT SCALE DRAWING	SCALE 6 : 1	SHEET 1 OF 1	

8

7

6

5

4

3

2

1