

THIS DOCUMENT AND THE DATA DISCLOSED HEREIN OR HEREWITH IS NOT TO BE REPRODUCED, USED, OR DISCLOSED IN WHOLE OR IN PART TO ANYONE WITHOUT PERMISSION OF VICOR CORP.

| REV. | DESCRIPTION | DATE | APPROVED |
|------|----------------------|---------------|----------|
| 1 | RELEASED PER E060516 | PEI 02/21/06 | MB |
| 2 | REVISED PER E080938 | SA 5/6/08 | REJH |
| 3 | REVISED PER E081632a | REJH 08/22/08 | CR |
| 4 | REVISED PER E100320a | GCK 03/08/10 | BH |

WITHOUT SPACER

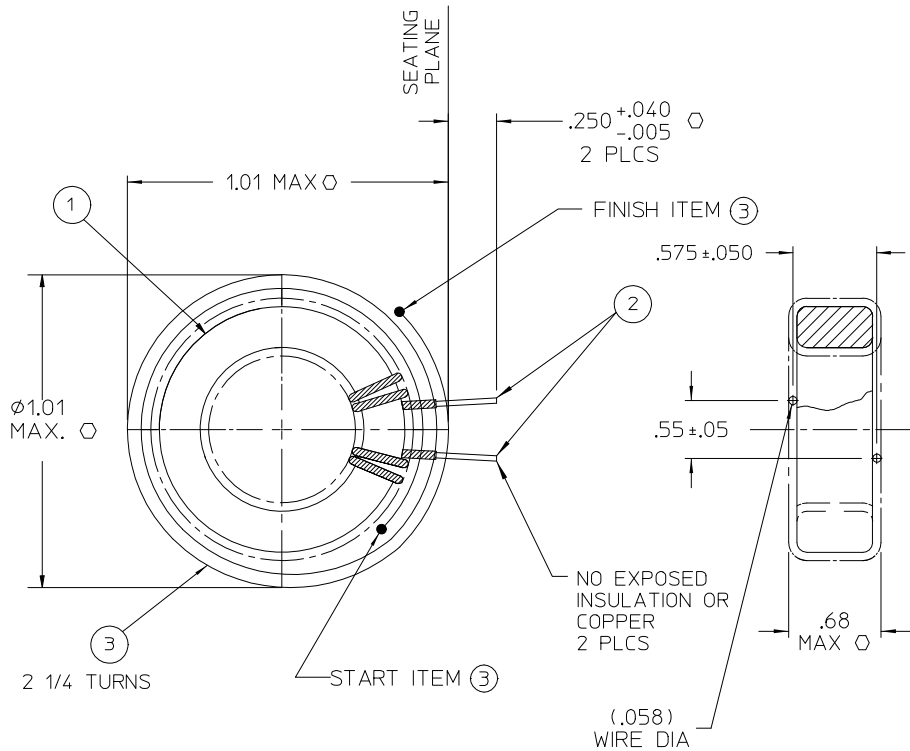

WITH SPACER

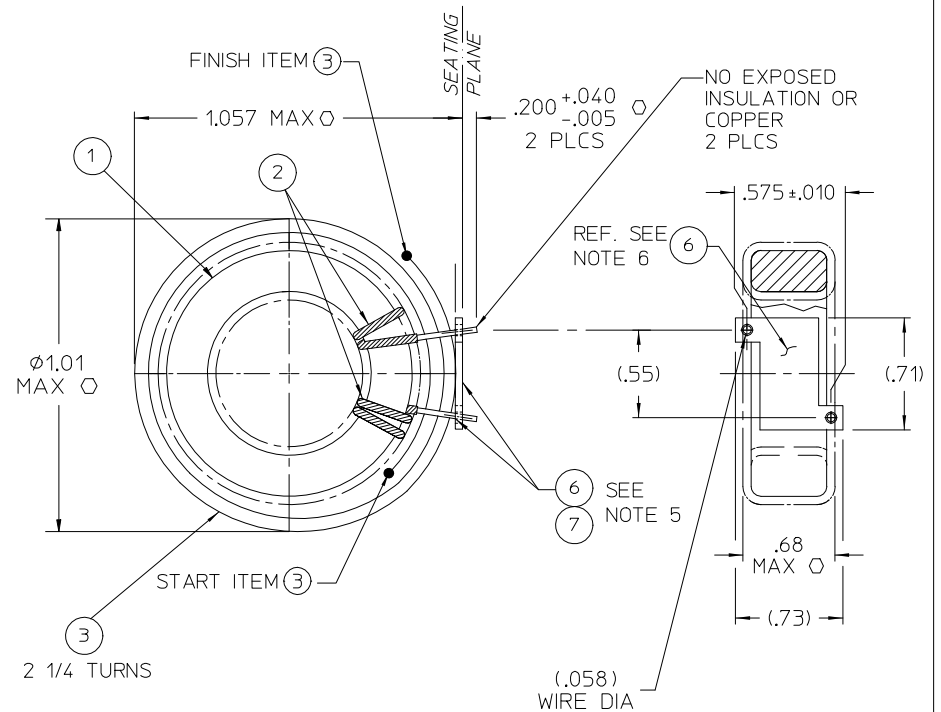

NOTES:

- ASSEMBLY TO BE FREE OF NICKS.
- WINDINGS TO BE EVENLY SPACED.
- RoHS COMPLIANT, LEAD FREE PER CST-0001 LATEST REVISION, MAGNETICS SECTION.
- GENERAL WORKMANSHIP STANDARDS FOR MAGNETIC COMPONENTS PER WS-0002.
- BOND SPACER (ITEM 6) TO DEVICE LEADS (2 PLACES), USING ADHESIVE (ITEM 7).
- ORIENTATION OF ITEM 6 TO BE AS SHOWN.
- ASSEMBLY MAY NOT HAVE ITEM 3 (TAPE).
- Ø DENOTES CRITICAL CHARACTERISTIC FOR LOT INSPECTION.

REF VICOR P/N 32011
 REF VICOR P/N 32012
 REF VICOR P/N 32013

| | | | | | |
|--|--|-------------------------|--------------------------|-------------------------|-----------------|
| DRAWN BY P.E.IENI | | DATE 11/14/05 | | | |
| UNLESS OTHERWISE SPECIFIED DIMENSIONS ARE IN INCHES - TOLERANCES ARE: FRACTIONS DECIMALS ANGLES ±1/64 .XX ±.01 XXX ±.005 °1° | | | | | |
| THIRD ANGLE PROJECTION | | SIZE C | FSCM NO. 67131 | DWG NO. 32015 | REV 4 |
| DO NOT SCALE DRAWING | | SCALE | | SHEET 1 OF 1 | |