

8

7

6

5

4

3

2

1

VICOR CONFIDENTIAL

THIS DOCUMENT AND THE DATA DISCLOSED HEREIN OR HEREWITH IS NOT TO BE REPRODUCED, USED OR DISCLOSED IN WHOLE OR IN PART TO ANYONE WITHOUT THE PERMISSION OF VICOR CORP.

REVISIONS

REV	DESCRIPTION		DATE	APPROVED
1	RELEASED PER E050348	PEI	11/15/05	ECF
2	REVISED PER E100872	KUK	06/30/10	DCS
3	2ND SHEET PER E101049	DCS	8/11/10	REJH

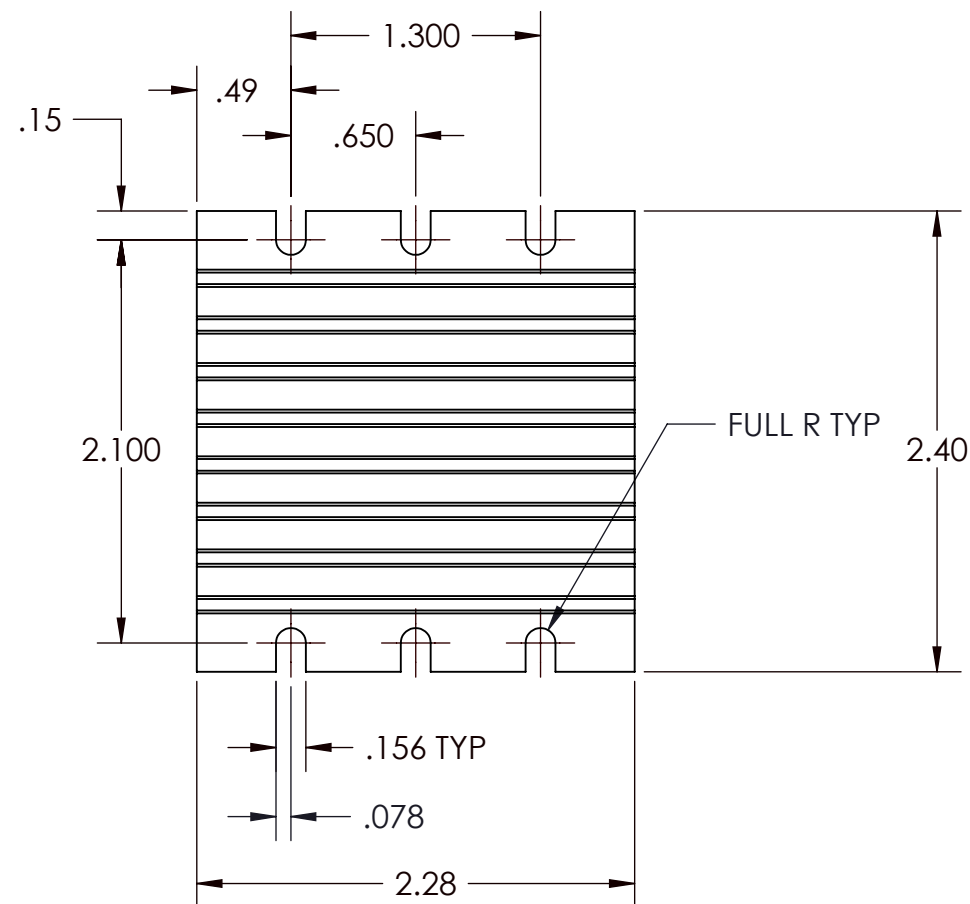
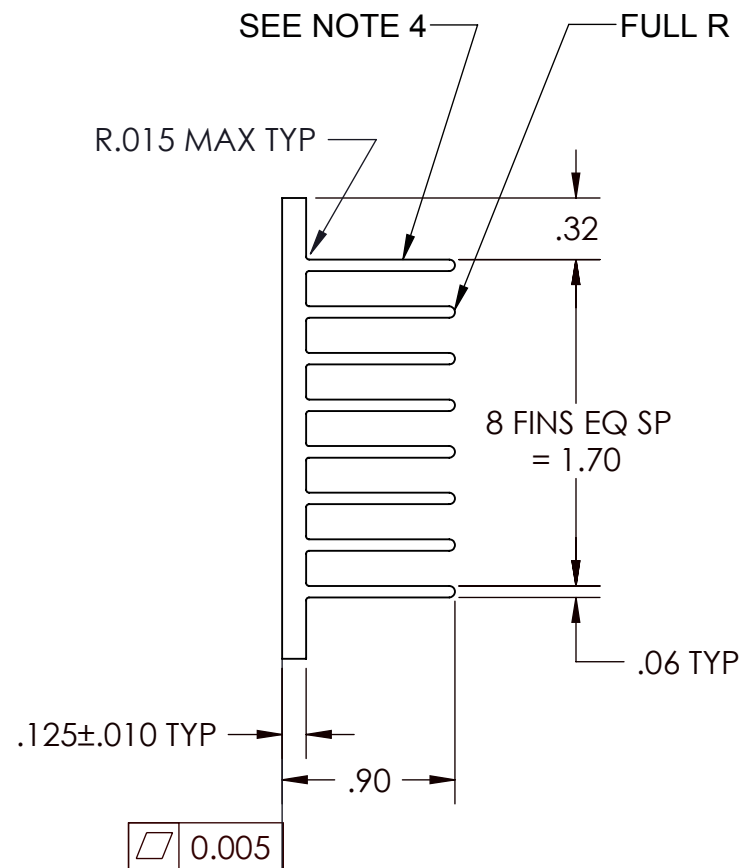

NOTES:

1. MATERIAL: ALUMINUM 6063-T5, MAKE FROM SAME EXTRUSION AS VICOR P/N 02111.
2. CLEAR FINISH, RoHS COMPLIANT, CHROMIUM FREE PER CST-0001, LATEST REVISION
3. REMOVE ALL LOOSE BURRS.
4. PERMANENTLY MARK PART NUMBER AND REVISION LEGIBLY IN AREA SHOWN.
5. ◊ DENOTE CRITICAL CHARACTERISTIC FOR LOT INSPECTION.
6. DIMENSIONS ARE INCHES ONLY.

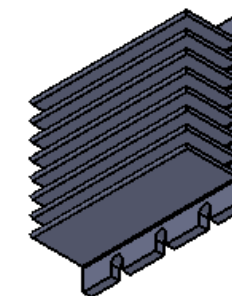

DRAWN	DATE
P.E.IENI	06/29/05



SWD

MATERIAL	UNLESS OTHERWISE SPECIFIED DIMENSIONS ARE INCH [MM] TOLERANCES ARE: DECIMALS ANGLES X.XX [X.X] = ±0.01 [0.25] ±1° X.XXX [X.XX] = ±0.005 [0.127]
FINISH	
THIRD ANGLE PROJECTION	
DO NOT SCALE DRAWING	

HEATSINK HORIZONTAL MINI MOD

SIZE	CAGE CODE	DWG NO	REV
B	67131	30191	3

SCALE 1 : 1 SHEET 1 OF 2

8

7

6

5

4

3

2

1

8

7

6

5

4

3

2

1

VICOR CONFIDENTIAL

THIS DOCUMENT AND THE DATA DISCLOSED HEREIN OR HEREWITH IS NOT TO BE REPRODUCED, USED OR DISCLOSED IN WHOLE OR IN PART TO ANYONE WITHOUT THE PERMISSION OF VICOR CORP.

REVISIONS

REV	DESCRIPTION	DATE	APPROVED
	SEE SHEET 1 OF 2		

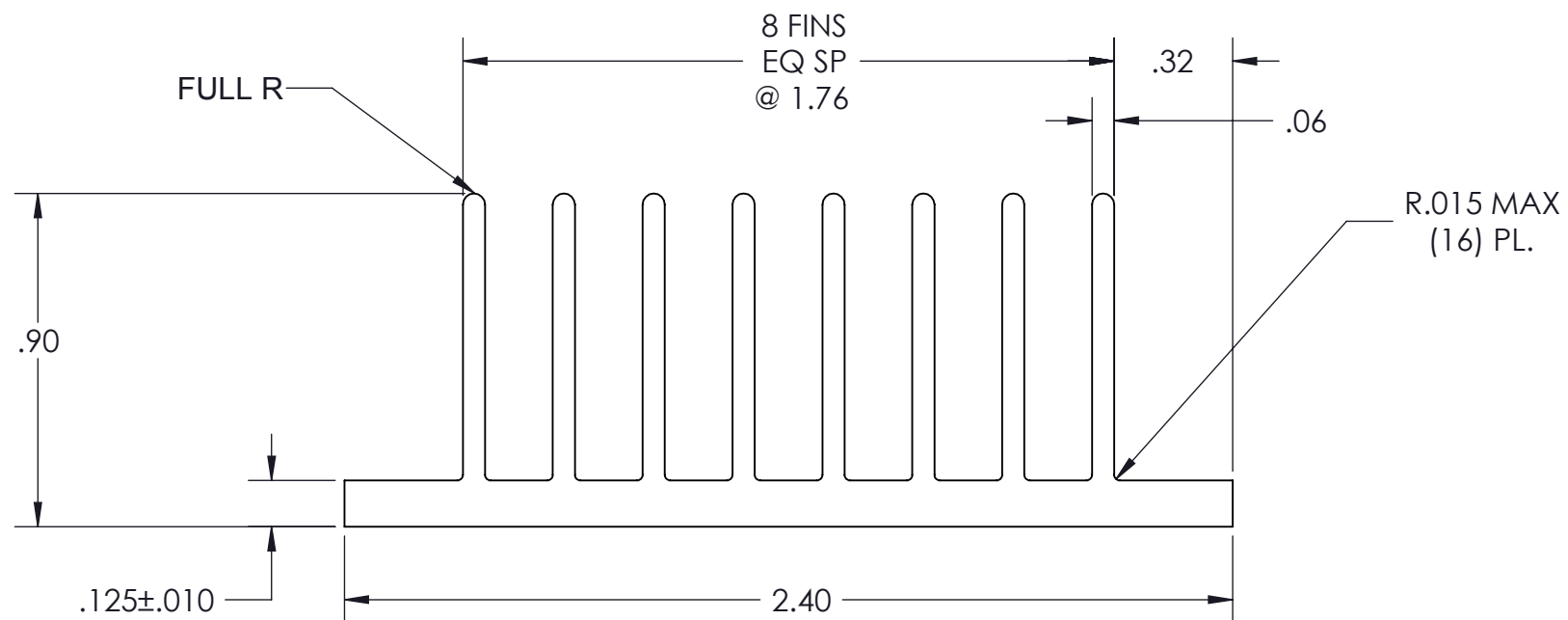

PROFILE COMMON FOR
08450
30191

NOTES:

1. MATERIAL: ALUMINUM 6063-T5
2. RoHS COMPLIANT PER CST-0001 LATEST REVISION.
3. BREAK ALL EDGES AND SHARP CORNERS.
4. DIMENSIONS ARE INCHES ONLY.

DRAWN	DATE
DAVID SCHMIDT	7/29/10

SWD

MATERIAL	UNLESS OTHERWISE SPECIFIED DIMENSIONS ARE INCH [MM] TOLERANCES ARE: DECIMALS ANGLES X.XX [X.X] = ±0.01 [0.25] ±1° X.XXX [X.XX] = ±0.005 [0.127]
SEE NOTES	
FINISH	THIRD ANGLE PROJECTION
SEE NOTES	DO NOT SCALE DRAWING

**HEATSINK HORIZONTAL
MINI MOD, EXTRUSION**

SIZE	CAGE CODE	DWG NO	REV
B	67131	30191	3

SCALE 2 : 1 SHEET 2 OF 2

8

7

6

5

4

3

2

1